

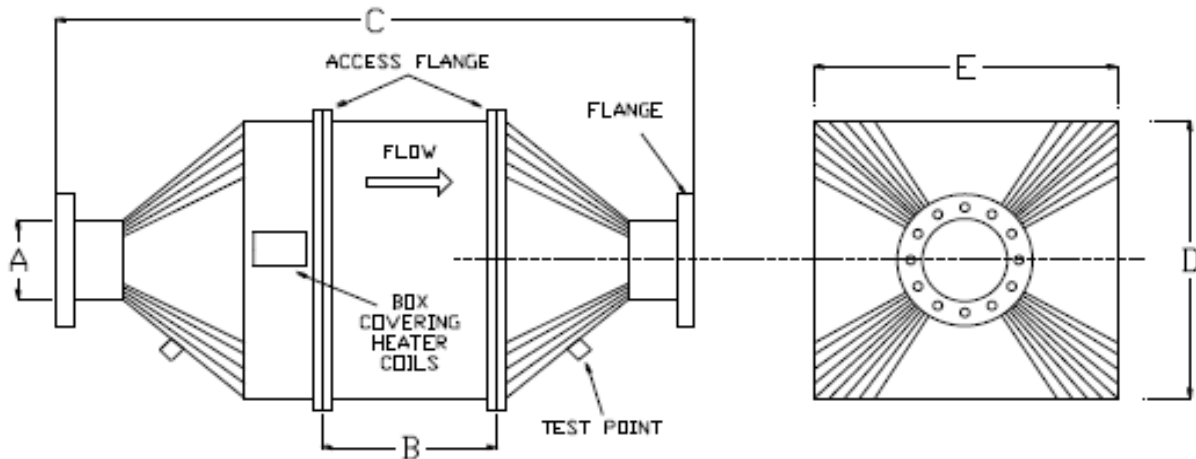

Soot Filter



ECISF

Model	A	B	C	D	E
ECISF 7	To Advise	525	1900	1100	1100
ECISF 8	To Advise	525	2000	1100	1100
ECISF 9	To Advise	525	2100	1100	1100
ECISF 10	To Advise	525	2200	1100	1400
ECISF 11	To Advise	525	2500	1450	1450
ECISF 12	To Advise	525	2500	1450	1450
ECISF 13	To Advise	525	2500	1450	1450

*Other sizes available upon request

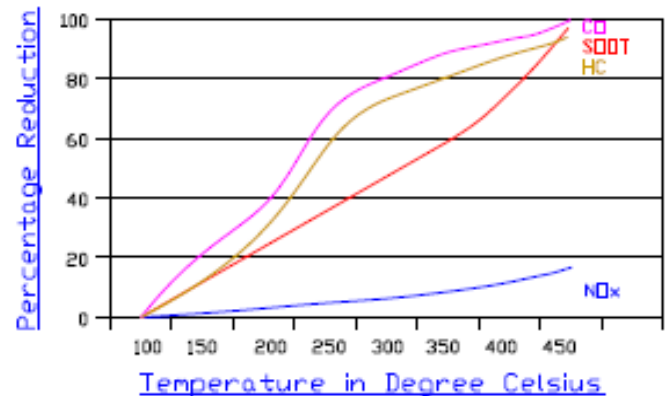

SPECIFICATION:

ECI soot filters are treated with catalyst so that it not only possesses the same properties as catalytic converters, it also effectively removes soot (black smoke) by at least 80%.

Black Smoke reduction is guaranteed under ANY conditions at a minimum of 80%.

Gas odors will be removed or reduced when the temperature of the soot filters reaches $\geq 180^{\circ}\text{C}$. This performance is consistent with catalytic converters.

PERFORMANCE (BASED ON FULL LOAD):

Carbon Monoxide	reduced by up to 90%
Hydrocarbons	reduced by up to 90%
Particulates	reduced by up to 80%
Soluble Organic Fraction	reduced by up to 85%

CHEMICAL REACTION DETAILS ARE AS FOLLOWS:-

$\text{CO} + \frac{1}{2} \text{O}_2$	$\rightarrow \text{CO}_2$
$\text{HC} + \frac{1}{2} \text{O}_2$	$\rightarrow \text{CO}_2 + \text{H}_2\text{O}$
$\text{PAH} + \text{O}_2$	$\rightarrow \text{CO}_2 + \text{H}_2\text{O}$
Aldehydes + O_2	$\rightarrow \text{CO}_2 + \text{H}_2\text{O}$

EXHAUST CONTROL INDUSTRIES (S) PTE LTD

69 TECH PARK CRESCENT, SINGAPORE 638073

TEL NO : +65 6744 2689 FAX NO : +65 6747 2217 E-MAIL : enquires@eci.com.sg WEBSITE : www.eci.com.sg

* ECI is protected by local and international trademark legislations. Patent Pending.